

Artificial Intelligence

Graphical Models

Marco Piastra

Chain Factorization

- From the definition of conditional probability

$$P(A, B, C, D, \dots) = P(A)P(B|A)P(C|A, B)P(D|A, B, C) \dots$$

Any joint probability distribution can be factorized in a way such that each factor is a *univariate* (i.e. of one random variable only) conditional distribution.

The factorization depends on the definition an arbitrary *sequence* of the *random variables*

Such factorization is not *unique*: any sequence produces a legitimate factorization of the same kind

Graphical models (*Bayesian Networks*)

Structure and numbers, instead of just numbers

■ A structured, pre-numerical representation of a joint probability

Each graphical model is an oriented graph

- nodes are *random variables*
- arcs represent *dependence*

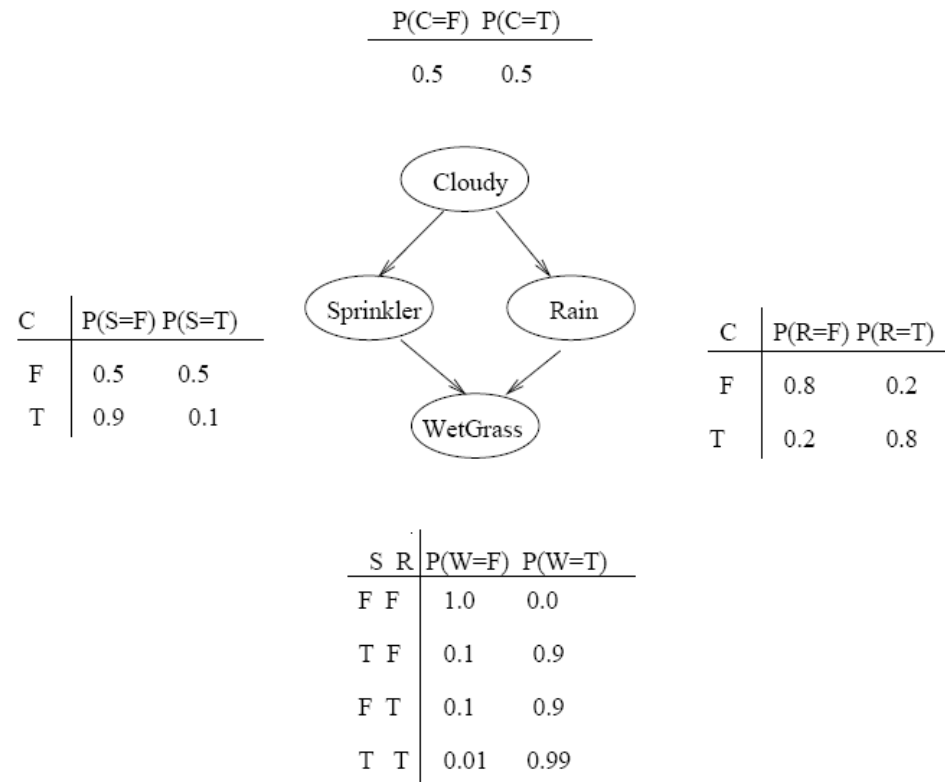

A complete specification
of a joint probability would require
 $2^4 = 16$ values

The values in figure are just 9

From graphical models to joint probability

Joint probability factorization

A chain factorization like the following is always allowed

$$P(C, S, R, W) = P(C)P(S|C)P(R|C, S)P(W|C, S, R)$$

Hint: apply the definition of conditional probability repeatedly (such factorization is not unique)

Factorization for a graphical model

$$P(X_1, X_2, \dots, X_n) = \prod_i P(x_i \mid \text{parents}(X_i))$$

where $\text{parents}(X_i)$ are the nodes from which there is an entry arc to X_i

C	P(S=F)	P(S=T)
F	0.5	0.5
T	0.9	0.1

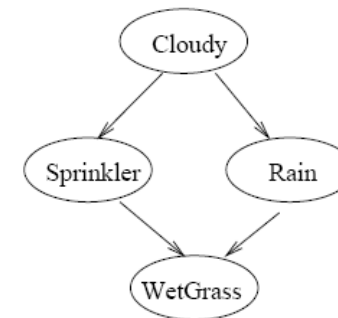

C	P(R=F)	P(R=T)
F	0.8	0.2
T	0.2	0.8

For this example, the above rule produces:

$$P(C, S, R, W) = P(C)P(S|C)P(R|C)P(W|S, R)$$

Note the difference from above

Independence assumptions: $\langle R \perp S \mid C \rangle, \langle W \perp C \mid R, S \rangle$

S	R	P(W=F)	P(W=T)
F	F	1.0	0.0
T	F	0.1	0.9
F	T	0.1	0.9
T	T	0.01	0.99

Graphical models and conditional independence

■ *D-separation (Dependency-separation)*

i.e. how to read a graphical model

In a graphical model

Two nodes X and Y are conditional independent given a set of nodes $\{Z_k\}$ when **all** paths are blocked (see below)

A path between X e Y is blocked if:

- 1) It is either a sequence $X \rightarrow \dots Z_i \dots \rightarrow Y$
or a *fork* $X \leftarrow \dots Z_i \dots \rightarrow Y$
($Z_i \in \{Z_k\}$)
- 2) It is a *join* $X \rightarrow \dots N \dots \leftarrow Y$ where neither N
nor all the *descendants* of N belong to $\{Z_k\}$

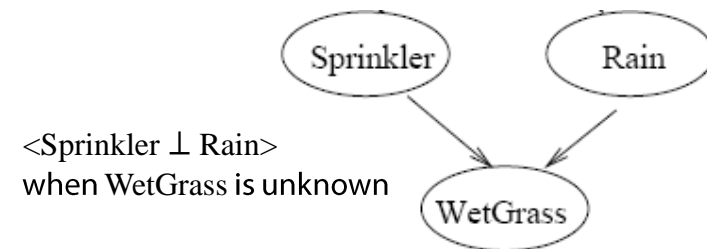
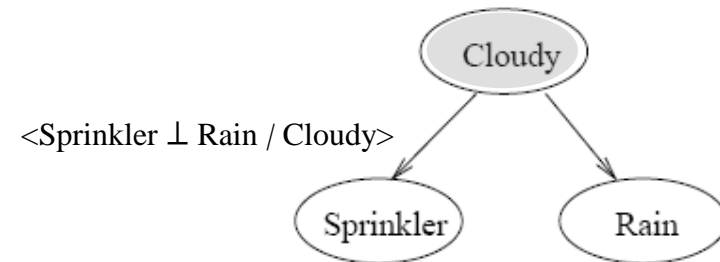
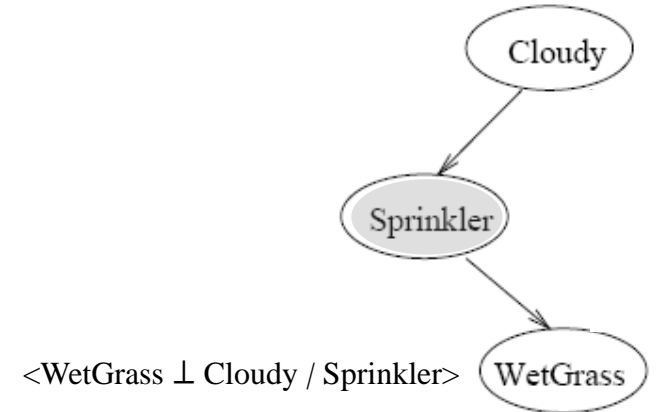

Explaining Away

A few more words on condition 2) of *D-separation*

Graphical model, with a *join*

Joint probability, from the graph:

$$P(X, Y, Z) = P(X)P(Y)P(Z|X, Y)$$

Marginal probability w.r.t X and Y (Z unknown):

$$P(X, Y) = P(X)P(Y) \sum_z P(Z|X, Y) = P(X)P(Y)$$

Therefore X e Y are *marginally independent*

But when Z is known, then X and Y are *dependent*:

$$P(X, Y | Z=v) = \frac{P(X, Y, Z=v)}{P(Z=v)} = \frac{P(X)P(Y)P(Z=v|X, Y)}{\sum_{X, Y} P(X)P(Y)P(Z=v|X, Y)}$$

It is not a paradox.

Example:

X and Y are two tosses of the same coin: $Z=1$ if the result is the same, $Z=0$ otherwise.

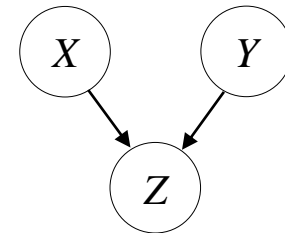

Example of graphical models

- Complete dependency

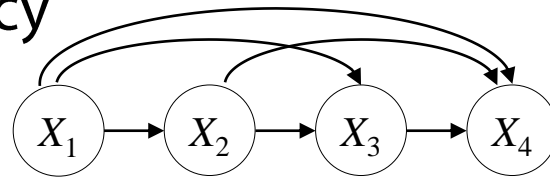

$$P(X_1, X_2, X_3, X_4) = P(X_1)P(X_2 | X_1)P(X_3 | X_1, X_2)P(X_4 | X_1, X_2, X_3)$$

- Markovian model

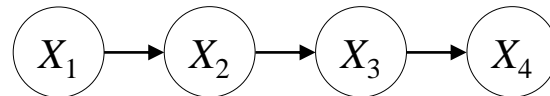

$$P(X_1, X_2, X_3, X_4) = P(X_1)P(X_2 | X_1)P(X_3 | X_2)P(X_4 | X_3) = P(X_1) \prod_{i=2}^n P(X_i | X_{i-1})$$

- 'Hidden' Markovian model

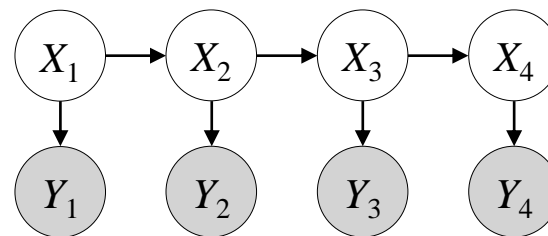

Typically, nodes X_i are *hidden*, in the sense of *non-observable* (see later, about *learning*)

$$\begin{aligned} P(X_1, X_2, X_3, X_4, Y_1, Y_2, Y_3, Y_4) &= P(X_1)P(Y_1 | X_1)P(X_2 | X_1)P(Y_2 | X_2)P(X_3 | X_2)P(Y_3 | X_3)P(X_4 | X_3)P(Y_4 | X_4) \\ &= P(X_1)P(Y_1 | X_1) \prod_{i=2}^n P(X_i | X_{i-1})P(Y_i | X_i) \end{aligned}$$

Example: *anti-spam filter*

Typically (e.g. Mozilla Thunderbird): '*Naive (Discrete) Bayesian Classifier*'

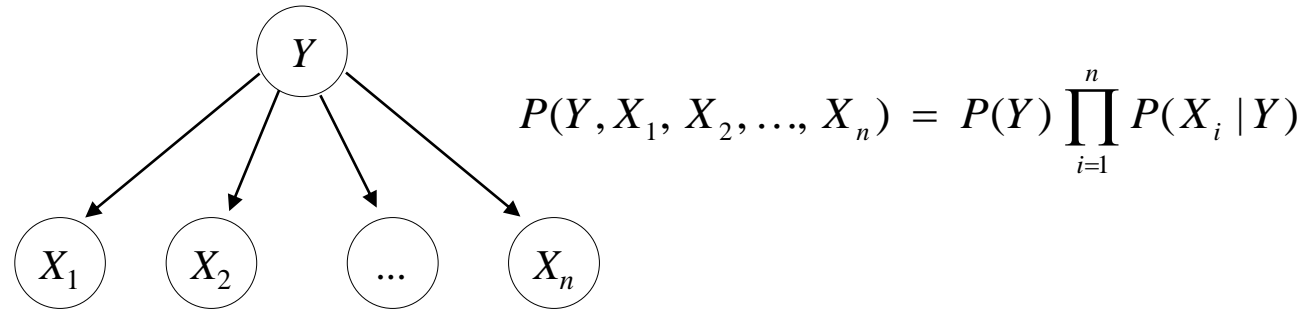

Anti-spam filter:

- All random variables are *binomial* (value: either 0 or 1)
- Y represents the class of the message: 1 *spam*, 0 *not-spam*
- Each X_i represents the occurrence of the i word in the message

Assume (*for now*) that the probabilities are given

As we will see, finding the '*right*' numbers is a *learning* problem (see after)

Inference in the *anti-spam filter*

$$P(Y, X_1, X_2, \dots, X_n) = P(Y) \prod_{i=1}^n P(X_i | Y)$$

Given a message with occurrence values $\{X_k\}$,
the class with the highest conditional probability is determined

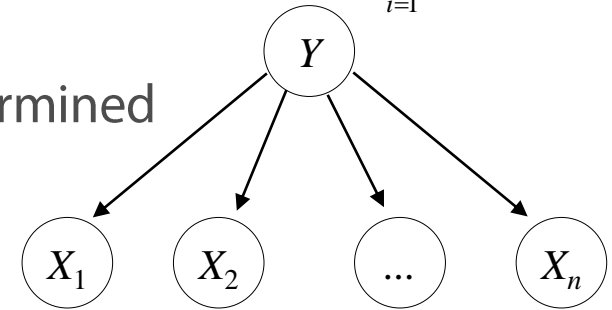

The message is *spam* if $\frac{P(Y=1 | \{X_k\})}{P(Y=0 | \{X_k\})} > \lambda$

Note that:

$$P(Y=1 | \{X_k\}) \stackrel{\text{Bayes' Theorem}}{=} \frac{P(\{X_k\} | Y=1)P(Y=1)}{\sum_Y P(\{X_k\} | Y)P(Y)} = \frac{P(Y=1) \prod_k P(X_k | Y=1)}{\sum_Y P(Y) \prod_k P(X_k | Y)}$$

Conditional independency

Therefore:

$$\frac{P(Y=1 | \{X_k\})}{P(Y=0 | \{X_k\})} = \frac{P(Y=1)}{P(Y=0)} \prod_k \frac{P(X_k | Y=1)}{P(X_k | Y=0)}$$

The logarithm is used to simplify computations:

$$\log \frac{P(Y=1 | \{X_k\})}{P(Y=0 | \{X_k\})} = \log \frac{P(Y=1)}{P(Y=0)} + \sum_k \log \frac{P(X_k | Y=1)}{P(X_k | Y=0)}$$

An aside: plate notation

A shorthand notation for graphical models

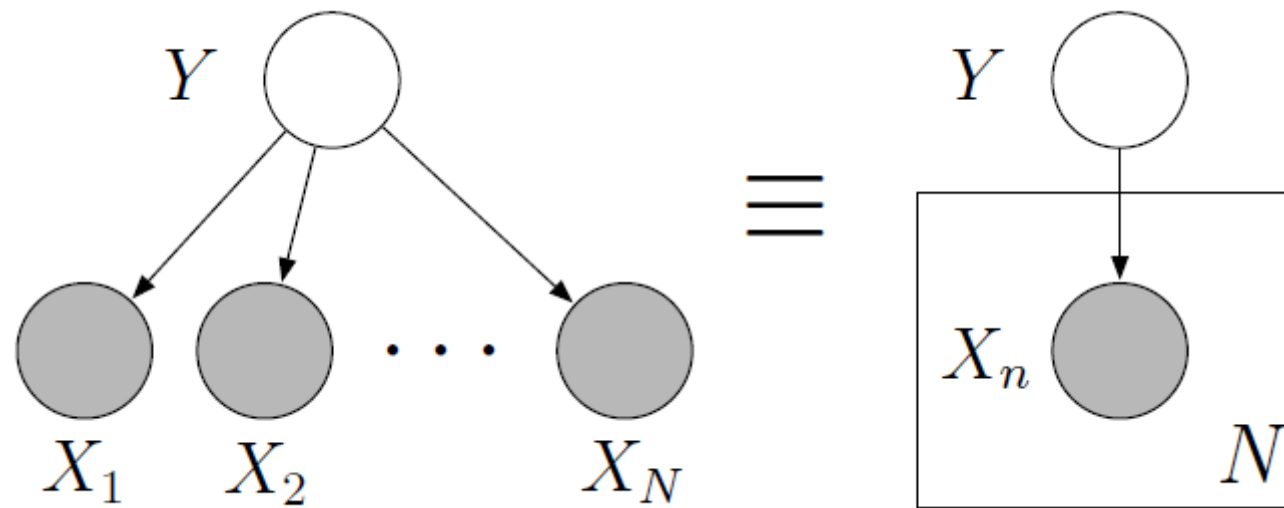

Building a graphical model

- Step 1

Defining the nodes, i.e. the random variables

T : (tampering)

F : (fire)

A : (alarm)

S : (smoke)

L : (leaving)

R : (report)

Building a graphical model

■ Step 2

Defining the structure, i.e. the graph

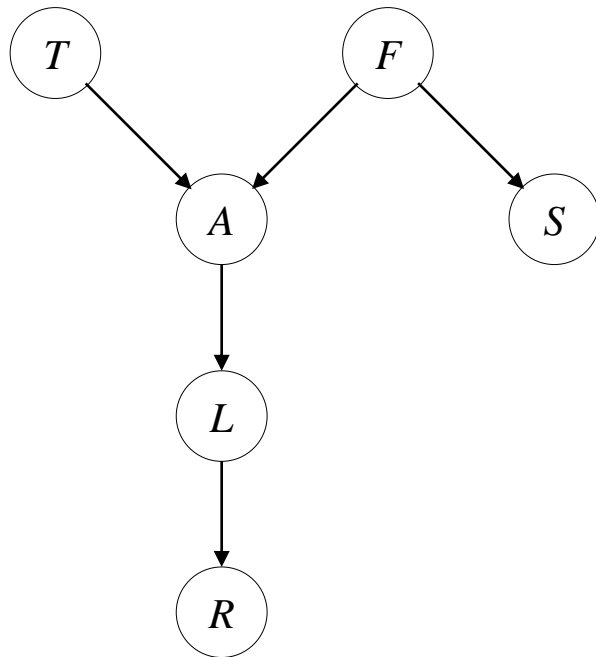

We are thus saying that:

$\langle T \perp F \rangle$ (but they become dependent when any of A , L or R are known)

$\langle A \perp S \mid F \rangle$

$\langle L \perp T \mid A \rangle$

$\langle L \perp F \mid A \rangle$

$\langle A \perp R \mid L \rangle$

T : (*tampering*)

F : (*fire*)

A : (*alarm*)

S : (*smoke*)

L : (*leaving*)

R : (*report*)

Building a graphical model

■ Step 3

Defining *conditional probability tables – CPTs*

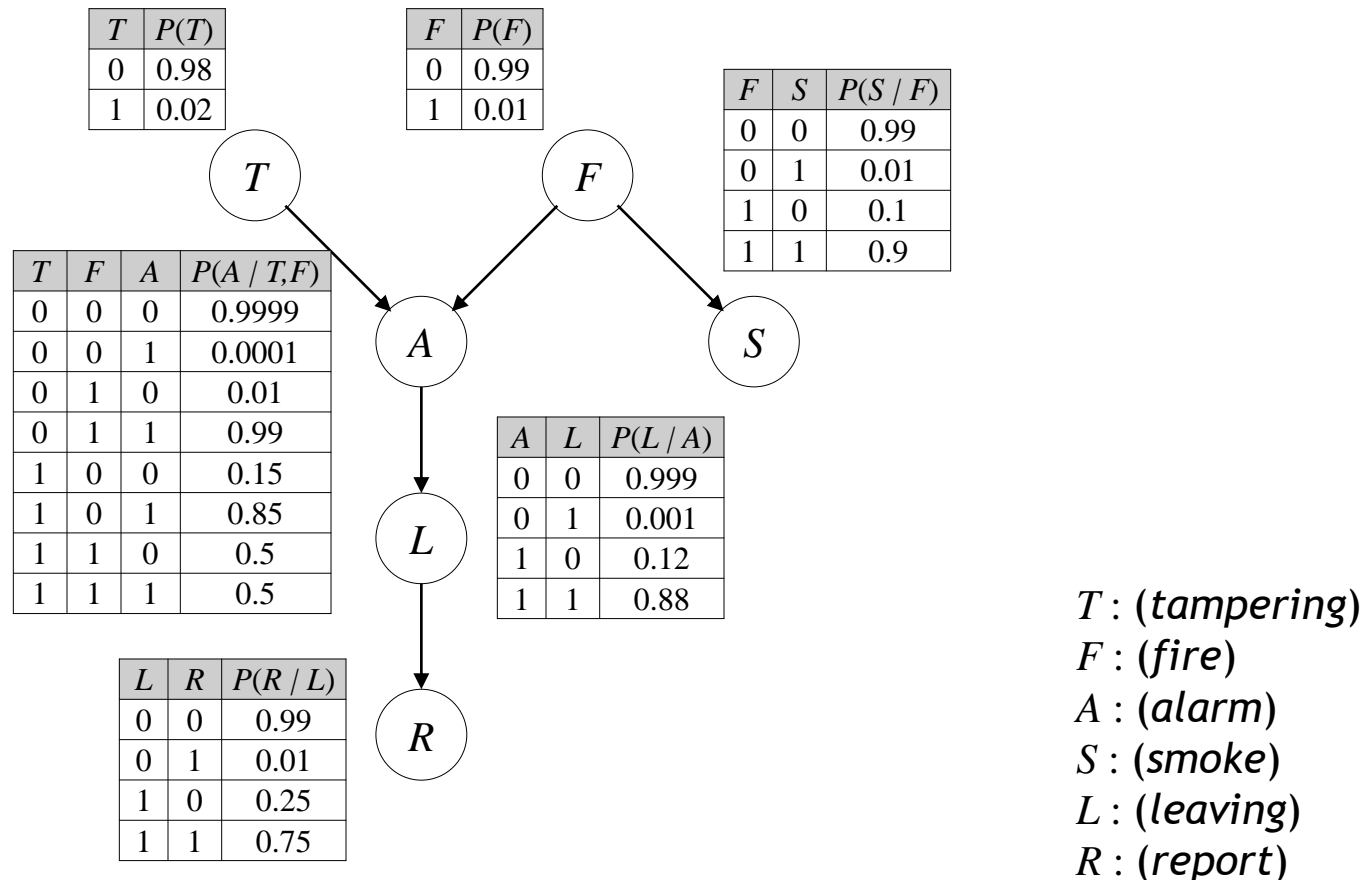

Probabilistic inference

Step 4

Consider a specific problem

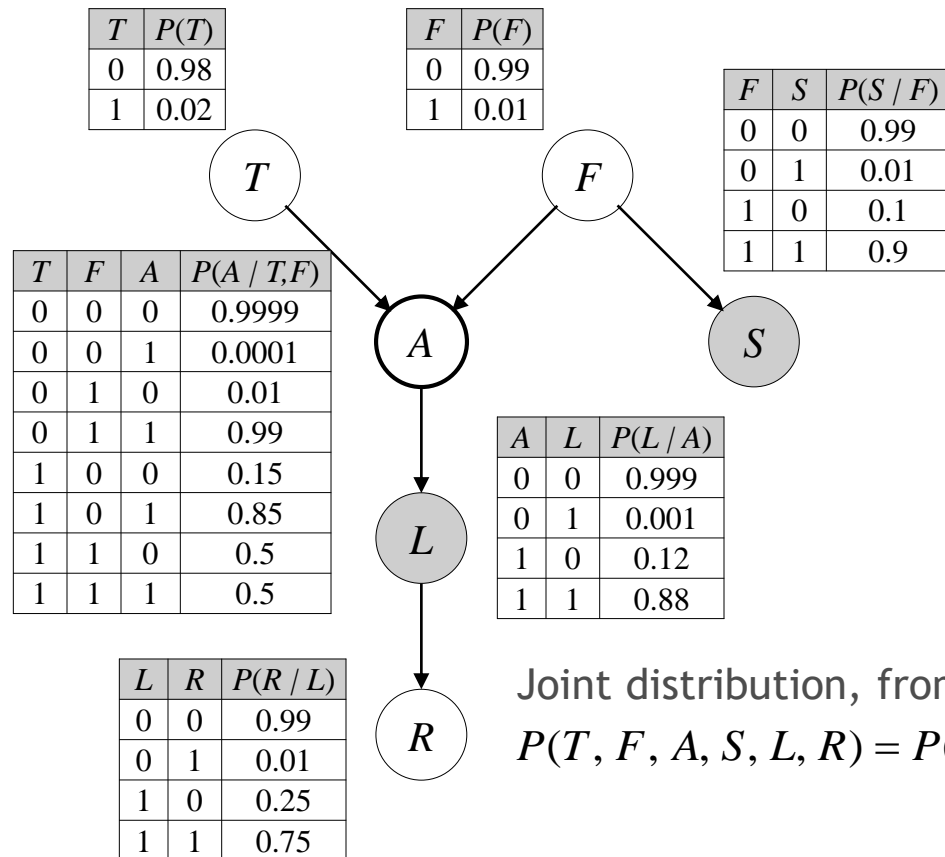

Example: finding A given $L=1$ e $S=0$

$$P(A | L=1, S=0) = \frac{P(A, L=1, S=0)}{P(L=1, S=0)}$$

Joint distribution, from the graph:

$$P(T, F, A, S, L, R) = P(T)P(F)P(A | T, F)P(S | F)P(L | A)P(R | L)$$

Probabilistic inference

Step 5

Computing the answer

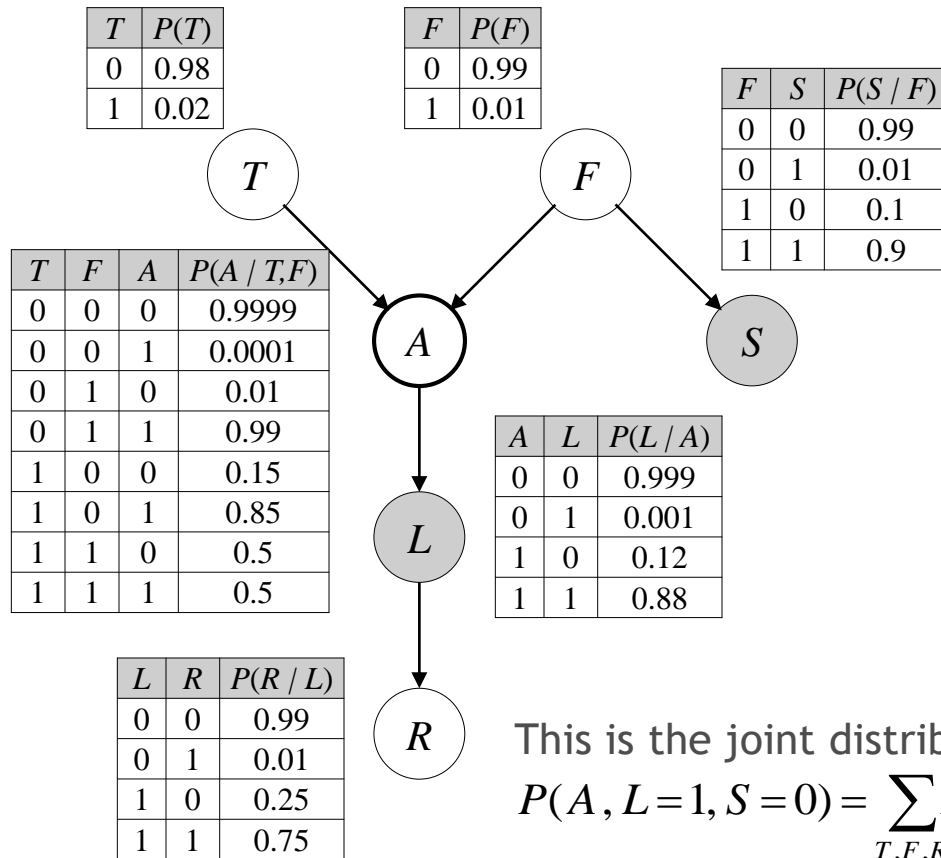

Note that:

$$P(A | L=1, S=0) = \frac{P(A, L=1, S=0)}{P(L=1, S=0)}$$

This is a normalizing term:
it can be computed from

$$P(A, L=1, S=0)$$

In fact:

$$P(L=1, S=0) = \sum_A P(A, L=1, S=0)$$

Typically, the most time-consuming computations
in an inference problem are marginalizations

This is the joint distribution to be computed:

$$P(A, L=1, S=0) = \sum_{T, F, R} P(T)P(F)P(A | T, F)P(S=0 | F)P(L=1 | A)P(R | L=1)$$

Probabilistic inference

Step 5

Computing the answer

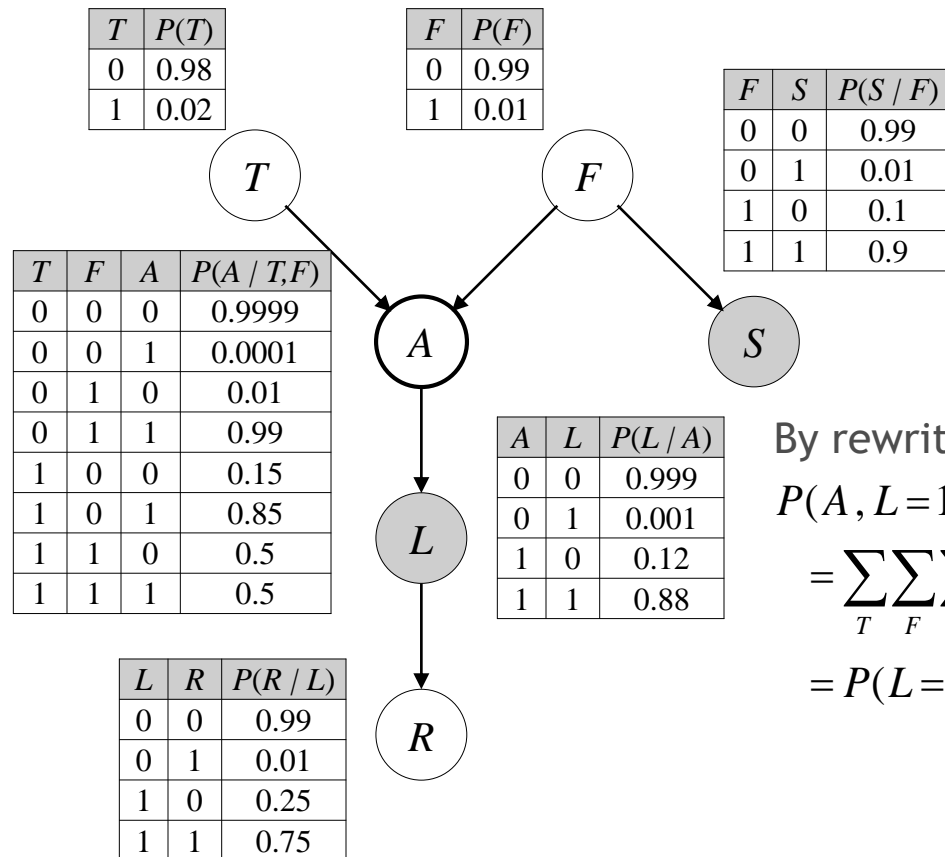

By rewriting the joint distribution:

$$P(A, L=1, S=0)$$

$$= \sum_T \sum_F \sum_R P(L=1|A)P(A|T,F)P(T)P(F)P(S=0|F)P(R|L=1)$$

$$= P(L=1|A) \sum_T \sum_F P(A|T,F)P(T)P(F)P(S=0|F) \sum_R P(R|L=1)$$

 This sum has value 1
 This is not surprising
 given that $\langle A \perp R | L \rangle$

Probabilistic inference

Step 5

Computing the answer

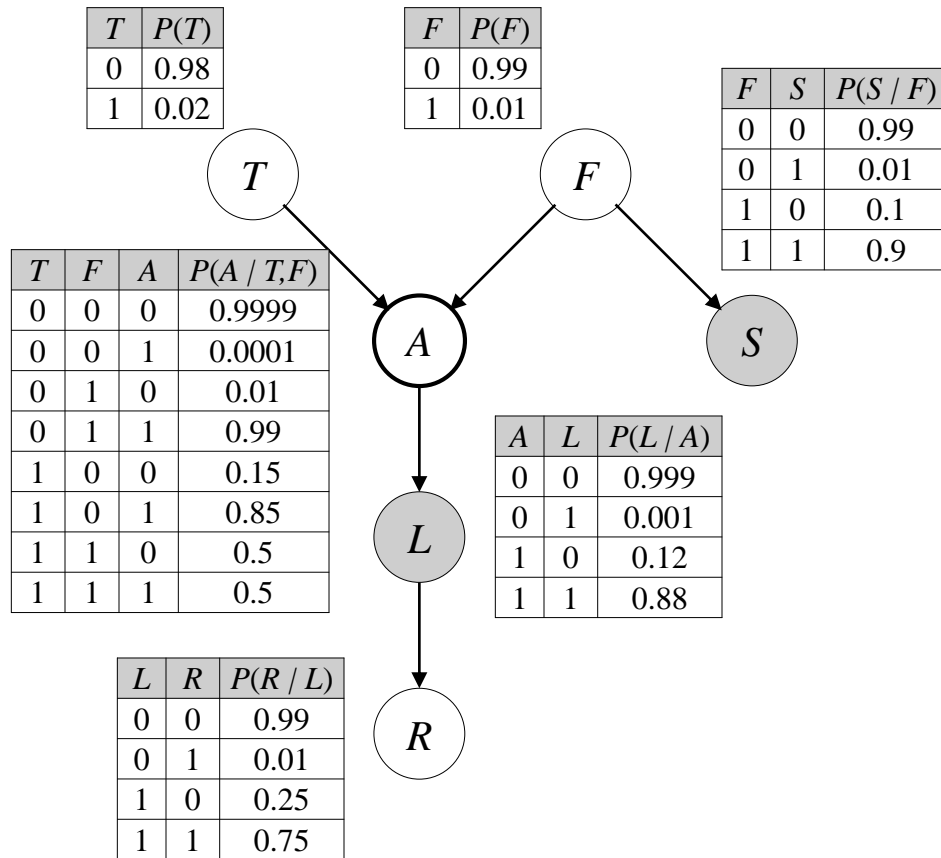

$$P(A, L=1, S=0)$$

$$= P(L=1 | A) \sum_T \sum_F P(A | T, F) P(T) P(F) P(S=0 | F)$$

By convention, we write:

$$P(A, L=1, S=0) = f_{T,F,S=0}(A) f_{L=1}(A)$$

where the f are the *factors* of the method also known as *elimination of variables*:

$$f_{T,F,S=0}(A) := \sum_T \sum_F P(A | T, F) P(T) P(F) P(S=0 | F)$$

$$f_{L=1}(A) := P(L=1 | A)$$

Note in passing that *factors* f are not probabilities (i.e. they do not sum to 1).

Probabilistic inference

■ Step 5

Computing the answer

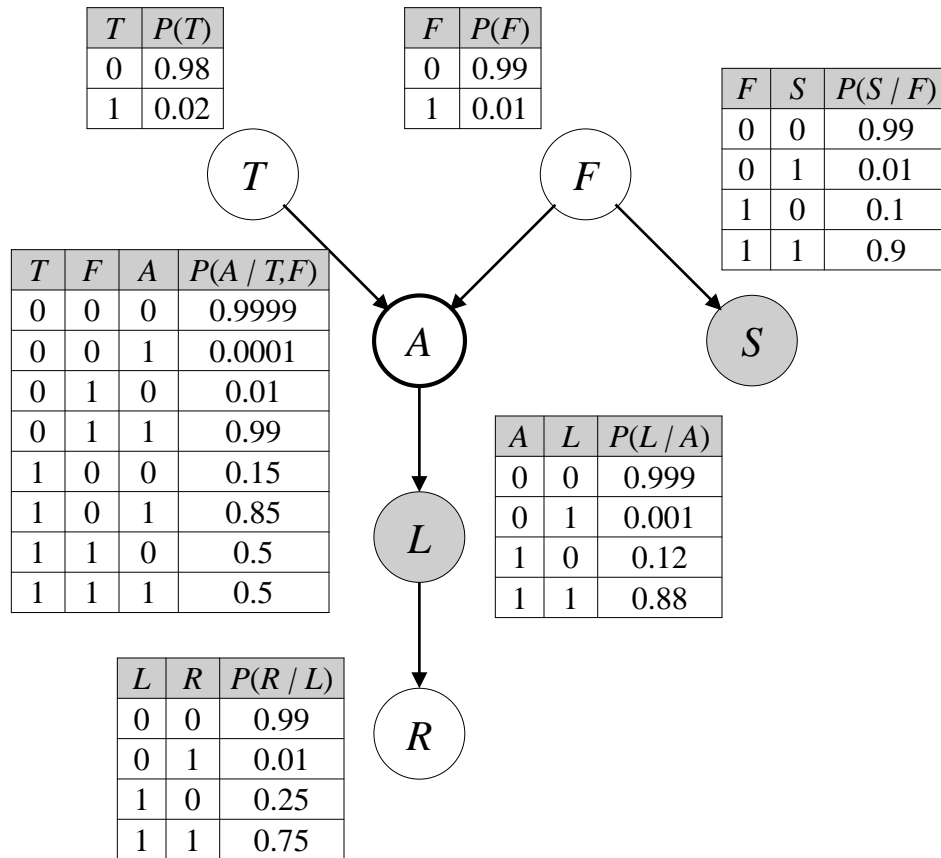

Note that:

$$P(A, L=1, S=0) = f_{T,F,S=0}(A) f_{L=1}(A)$$

This factor comes from
the *parents* of A

This factor comes from
the *descendants* of A

This is true
for any node A that *d-separates* the graph

Variable elimination for graphical models

■ General idea

Write the joint probability of the query in the form:

$$P(\{X_f\}, \{X_e\}) = \sum_{\{X_r\}} \prod_{X_i} P(X_i \mid \text{parents}(X_i))$$

- 1) Find the best ordering of terms for the marginalization of irrelevant variables:
- 2) Move summations 'inside' the product as much as possible (i.e. find *factors* f)
- 3) Compute factors (i.e. by sum of products) and obtain numbers (i.e. *terms*)
- 4) Plug these *terms* into the product and obtain a simpler form for $P(\{X_f\}, \{X_e\})$
- 5) Wrap it up and compute the response:

$$P(\{X_f\} \mid \{X_e\}) = \frac{P(\{X_f\}, \{X_e\})}{\sum_{\{X_f\}} P(\{X_f\}, \{X_e\})}$$

Remember: the method is NP-complete (anyway)

Graphical models as a probabilistic method

■ Advantages

Independence in the graph model
↓
implies independence in the joint probability distribution

Correctness (of representation) $\langle \{X\} \perp \{Y\} \mid \{Z\} \rangle_{GM} \Rightarrow \langle \{X\} \perp \{Y\} \mid \{Z\} \rangle_{JPD}$

In a finitary setting, they are always computable

Graph models are easy to read (compared to JPDs)

■ Limitations

No *abstraction* over multiplicity

(i.e. no First-order Logic equivalent – see also <http://www.pr-owl.org/basics/bn.php#reasoning>)

- Consider you receive multiple reports (random variable R) of fire: do they support each other? Which ones are reliable?
- Time sequences or specific patterns of variable size

No *completeness* $\langle \{X\} \perp \{Y\} \mid \{Z\} \rangle_{JPD} \not\Rightarrow \langle \{X\} \perp \{Y\} \mid \{Z\} \rangle_{GM}$

- *Counterexample: no DAG can represent*

$$\langle X_1 \perp \{X_2, Y_2\} \rangle, \quad \langle X_2 \perp \{X_1, Y_1\} \rangle$$

Not all JPDs can be faithfully represented
by a graph model

without introducing some further independence relation

(no closure under marginalization - see also https://projecteuclid.org/download/pdf_1/euclid.aos/1031689015)